

**Booster sets with 2 to 4 LCR pumps  
50 Hz**



**PUMPS • MOTORS**

ISO 9001 Company



**Pumping Solution**

# Contents

## Booster sets with 2 to 4 LCR pumps

## Aquapack 1000

### Product data

Introduction	3
Applications	3
Features and benefits	3
Type key	3
Operating conditions	4
Other versions on request	4
Function	4
LE 1000 Controller for 2 to 4 pumps	4
LE 1000V Controller for 2 to 4 pumps	4
Pump	5
Motor	5
Shaft seal	5
Performance range	6

### Construction

Construction	7
Dimensions and weights	7
Flange dimensions	7
System components	7
Materials LCR, LCRI, LCRN 2, 3, 5, 10, 15 and 20	8
Materials LCR, LCRN 32 and 45	8

### Installation

Mechanical installation	9
Electrical installation	9

### Performance curves

LCR 2	10
LCR 3	11
LCR 5	12
LCR 10	13
LCR 15	14
LCR 20	15
LCR 32	16
LCR 45	17

### Dimensions and weights

Booster set with 2 pump	18
Booster set with 3 pump	20
Booster set with 4 pump	22

### Diaphragm tank

Diaphragm tank selection	24
--------------------------	----

# Product data

## Booster sets with 2 to 4 LCR pumps

## Aquapack 1000

### Introduction

Lubi **Aquapack 1000** booster sets consist of 2 to 4 identical vertical multistage (LCR) pumps mounted in parallel on a common base frame, control cabinet with motor protection and integrated **LE 1000** series controller.

These pumps are automatically operated according to system requirement by means of pressure switches (one for each pump). The setting of the pressure switches have to be within the optimal performance area of each pump model.

Automatic operation of one or more pumps with VFD control is optional.

Aquapack 1000 booster sets are supplied as complete, preassembled and tested systems including suction and discharge manifolds, isolating valves, non-return valves, pressure gauge and pressure switches.

To ensure stable operation the booster set must be fitted with a suitable diaphragm tank. To select the size of the diaphragm tank see section "Diaphragm tank selection" at page 24.

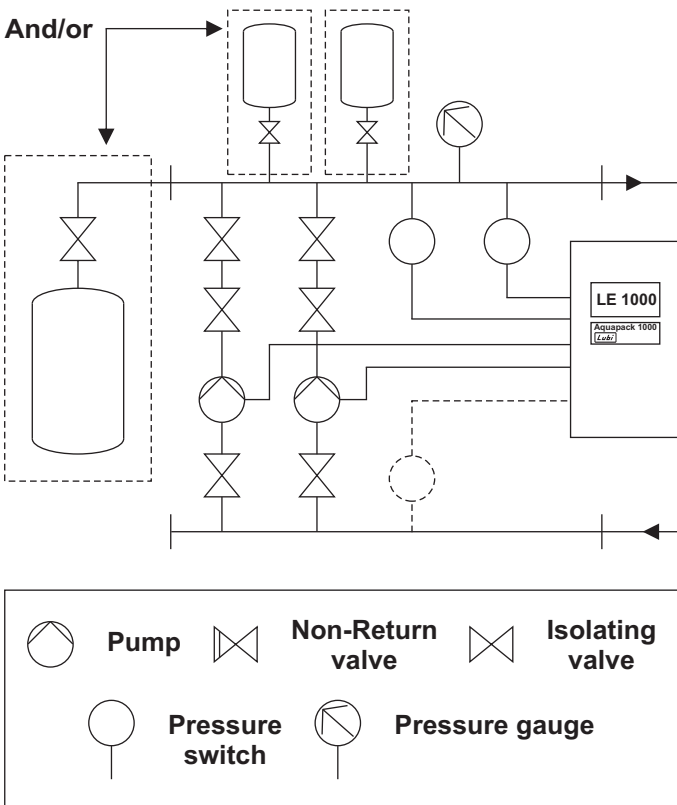

**Fig. 1** Aquapack 1000 pressure boosting system

Non-return valves can be fitted on the suction side on request.

### Applications

Lubi Aquapack 1000 booster sets are designed for the transfer and pressure boosting of clean water for community water supply, apartment complex, hotels, hospitals, industries, commercial buildings, schools, etc.

### Features and benefits

The state-of-the-art features introduced into this new vertical multistage pump generation offer the following benefits:

- High efficiency** Minimized energy cost
- Low NPSH** Improves suction capability
- Air handling** Reduces risk of dry-running
- Spacer coupling** Allows easy disassembly of motor from pump (for 11 kW motor onwards)
- Sleeve sealing** Provides high resistance to pressure pulses and withstands temperature fluctuations as well as external forces
- Tungsten carbide bearings** Wear resistance, improved dry-running capability and handling of thermal shocks enable longer operating time
- Reinforced shaft lock ring** Strong axial locking force and high torque lock system enable robust and reliable operation of rotating assembly

### Type key

Example	Aquapack 1000	G	SSC	2	LCR	2-3	3 x	400 V
Type								
/G : See System components								
/L : See System components								
/N : See System components								
SSC: On-off control								
VF1 : VFD control for 1 pump								
VF2 : VFD control for 2 pumps								
VF3 : VFD control for 3 pumps								
VF4 : VFD control for 4 pumps								
Number of pumps								
Pump type								
Voltage/frequency								

# Product data

## Booster sets with 2 to 4 LCR pumps

## Aquapack 1000

### Operating conditions

Flow range	: Up to 232 m <sup>3</sup> /h
Operating pressure	: max. 16 bar
Liquid temperature	: 0°C to +90°C
Ambient temperature	: 0°C to +40°C
Maximum suction lift (H):	

The maximum suction lift (H) can be calculated as follows:  
 $H = 10.33 \text{ m} - \text{NPSH of the pump} - \text{other suction losses} - \text{a safety margin of 0.5 metres.}$

Maximum inlet pressure:	6.0 bar
Power range	: Up to 30 kW per pump
DOL starting	: Up to 7.5 kW
SD starting	: 11 to 30 kW
Power supply	: 3 x 400 V, 50 Hz.

### Other versions on request

The following versions are available on request:

- Booster set with jokey pump
- Booster set with LCRI 2, 3, 5, 10, 15, 20 pumps
- Different material combination - see chapter System components
- Single-phase power supply: 1 x 230 V, 50 Hz
- Three-phase power supply: 3 x 230 V, 50 Hz
- Starting configuration other than standard
- 60 Hz.

### Function

When a tap is opened, water is taken from the diaphragm tank. Then the pressure drops to the first cut-in pressure, and the first pump is cut in. As the consumption rises, more pumps will be cut in until the performance of the pumps in operation corresponds to the requirement.

When the water consumption falls, the discharge pressure rises to the cut-out pressure and the LE 1000 Controller cuts out one pump.

As the consumption falls, more pumps will be cut out.

Please see fig. 2 which explains how the pumps will operate based on consumption of water.

### Example: Aquapack 1000 with 3 pumps

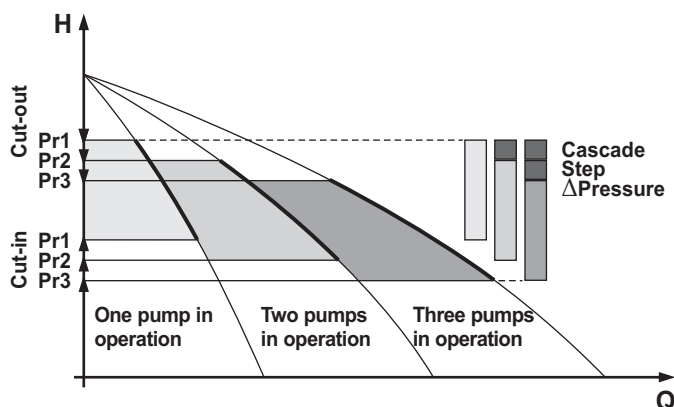

Fig. 2 Operation with cut-in and cut-out

### LE 1000 Controller for 2 to 4 pumps

The Lubi LE 1000 Controller supervises a given number of mains-operated pumps.

The LE 1000 Controller offers the following features/functions:

- Attractive control box with a dust proof & water proof IP 58 protection & lockable key.
- Cascade control, only the required number of pumps are in operation at any time.
- Highly reliable magnetic motor contactors.
- Single phase prevention & overload motor protection.
- Dry run protection & low pressure protection.
- Delay & minimum run timers to eliminate unnecessary pump cycle.
- Manual operation.
- Pump ON & pump Fault indication.
- Automatic alternation (changeover) of lead pump to ensure equal run time of all pumps.
- At the heart of the controller is a PLC controller with 5.7" Colour Touch Screen Display (HMI) to programme the Aquapack 1000 system as per the customer site requirement.

### LE 1000V Controller for 2 to 4 pumps

LE 1000V Controller is a premium series state of the art controller which offers all the features mentioned above of LE 1000 Controller.

This controller is additionally equipped with a Variable Frequency Drive (VFD) for customer required quantity of pumps. Following are the additional features with VFD Controller.

- A pressure transducer connected on the discharge manifold, provides a continuous feedback to the VFD to either increase or decrease the speed of the pump, to provide constant pressure during varying flow condition. These means that when demand for water reduces, the pump speed reduces which in turn reduces energy consumption. These feature provides the benefit of lower energy consumption to the customer.
- The Variable Frequency Drive also provides a smooth, ramp up of speed when the pump motor is started. These drastically reduces the starting current requirement for the pump motor. It also reduces wear and tear on motor bearings & pump rotating components.

LE 1000V Controller also provides a special feature which is called "Zero Flow/Demand" to avoid unnecessary running of pump motor at very low speeds. Whenever there is no demand of water there is a small leakage loss thru faucets which is detected by the controller and it shuts down the pump motor to save energy. When the pump motor is shut down the leakage losses as mentioned above are supplied by the water from the hydro pneumatic tank. Once the pressure in hydro pneumatic tank falls below a preset condition, the controller will start one of the pump shortly to boost up the pressure in the hydro pneumatic tank.

When the usage of water increases, again the controller will detect this and will start operating in a normal condition.

# Product data

## Booster sets with 2 to 4 LCR pumps

## Aquapack 1000



Fig. 3 LE 1000V Controller display for 2 to 4 pumps

### Protection

A pressure switch or a level switch at the suction side can be used as dry-running protection. When the water level or pressure has been restored, automatic or manual resetting is possible.

### Time control

To adapt the booster set operation to the actual conditions, the following settings can be made with the touch screen display:

**Start-up delay** : Prevents simultaneous start-up of all pumps.

**Stop delay** : Prevents simultaneous stop of all pumps.

**After-run delay**: Keeps pumps in operation for few seconds, after cut-out pressure is reached.

Time control is particularly convenient to reduce the number of starts and stops per hour, to prevent water hammer and negative pressure in the suction manifold as well as other problems that can arise under certain conditions.

### Pump

The LCR pumps are non-self-priming, vertical multistage centrifugal pumps.

The pump consists of a base and a pump head. The chamber stack and the outer sleeve are secured between the pump head and the base by means of tiebolts. The base has suction and discharge connections on the same level (in-line).

All pumps are equipped with a maintenance-free mechanical shaft seal.

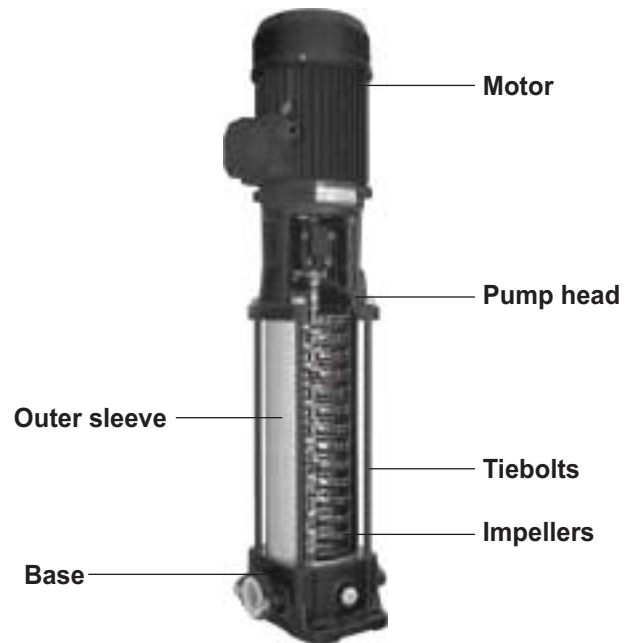

Fig. 4 LCR pump

### Motor

These pumps are fitted with a totally enclosed, fan-cooled, 2-pole motor with principal dimensions in accordance with the EN/IEC and DIN standards.

Electrical tolerances according to EN 60034/IEC 34.

### Electrical data

Mounting designation	Up to 4 kW: V 18 From 5.5 kW: V 1
Insulation class	F
Efficiency class	EFF 2
Enclosure class	IP 55
Supply voltage (Tolerance: $\pm 10\%$ )	For P <sub>2</sub> : 0.37 to 3 kW - 3 x 220-240/ 380-415 V For P <sub>2</sub> : 4 to 30 kW - 3 x 380-415 V
Supply frequency	50 Hz

### Motor protection

All motors are protected by the control panel of the booster set.

Three-phase motors from 3 kW upwards have a built-in thermistor (PTC) according to DIN 44082.

Single-phase motors have a built in thermal overload switch.

### Shaft seal

As standard the LCR pump is fitted with a BBQV shaft seal (Bellow type).

Shaft seal	Description	Max. Temperature range [°C]
BBQV	O-ring (Bellow), Carbon/SiC, FKM	-40°C to +120°C

# Product data

Booster sets with 2 to 4 LCR pumps

# Aquapack 1000

Performance range

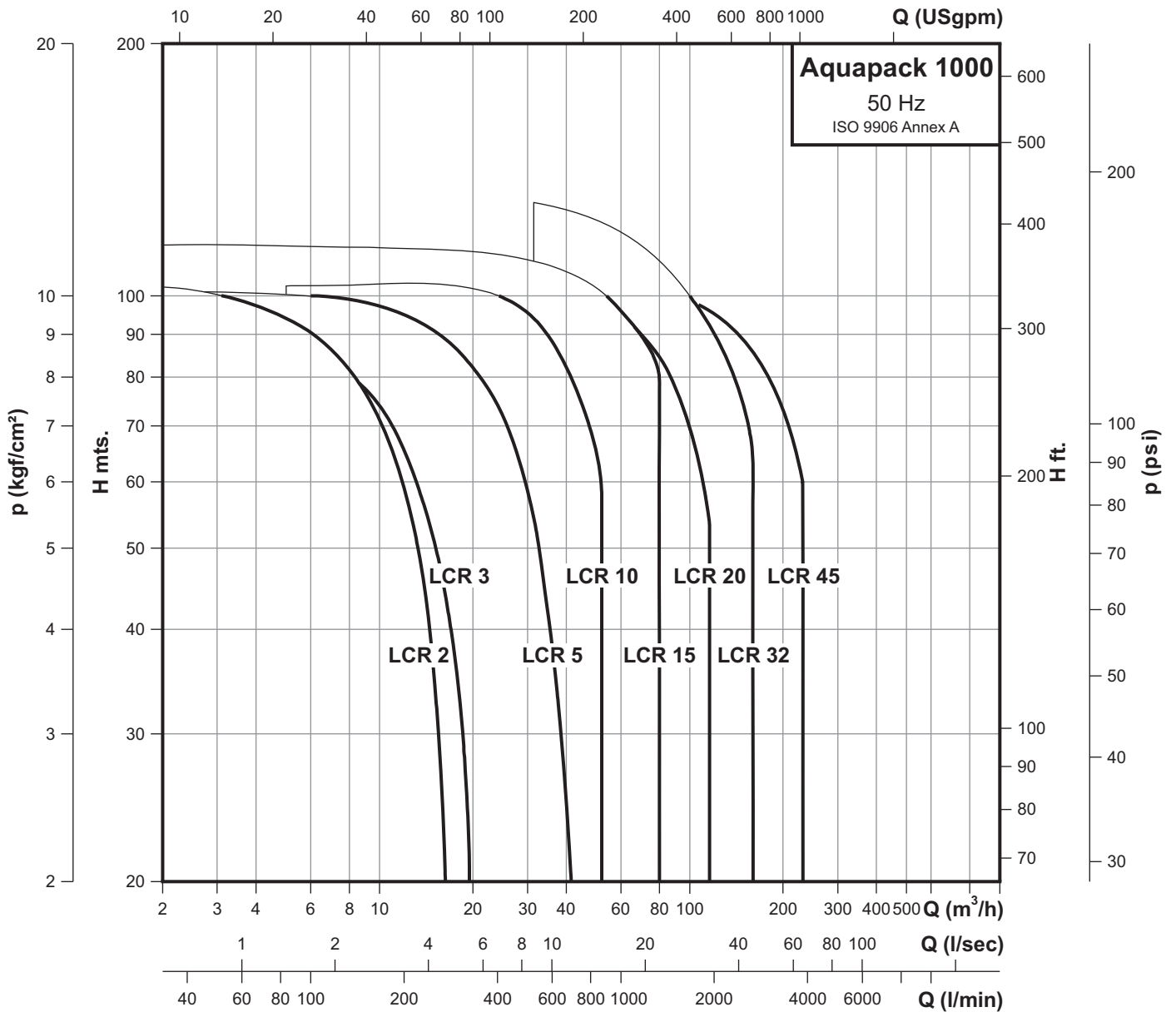

# Construction

## Booster sets with 2 to 4 LCR pumps

## Aquapack 1000

### Construction

Aquapack 1000 is built up on a common base frame. The pumps are fixed to the base frame by means of bolts. The control cabinets are divided into three groups based on construction.

- Systems with the control cabinet mounted on the pump base frame.
- Systems with the control cabinet mounted on a separate base frame.
- Systems with the control cabinet without a base frame, therefore suitable for floor mounting.

For further information, see the paragraph Dimensions.

A discharge manifold is mounted on the discharge side of the pumps. An isolating valve and non-return valve are mounted between the discharge manifold and the individual pumps. The non-return valve may be mounted on the suction side on request.

A suction manifold is mounted on the suction side of the pumps. An isolating valve is mounted between the suction manifold and the individual pumps.

### System components

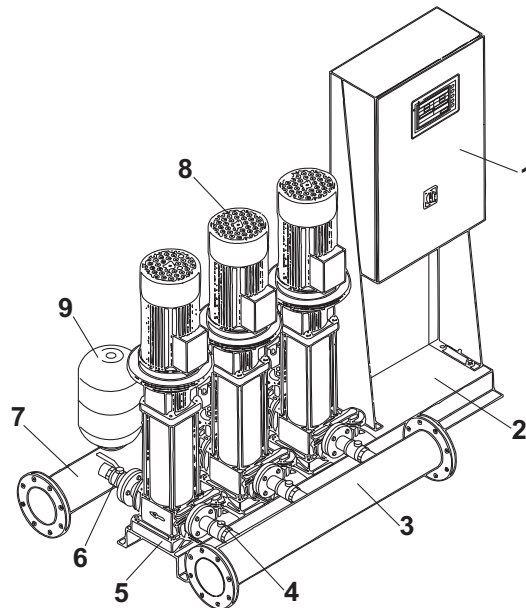

Fig. 5 System components

Pos.	Description	Qty.	Versions		
			“G”	“L”	“N”
1	Control panel	1	Metal, painted	Metal, painted	Metal, painted
2	Panel stand	2	Galvanized steel	Galvanized steel	1.4301 (AISI 304)
3	Suction manifold	1	Galvanized steel	1.4301 (AISI 304)	1.4401 (AISI 316)
4	Isolating valve	2 per pump	Brass NiCr- plated or cast iron	Brass NiCr- plated or cast iron	1.4401 (AISI 316) and cast iron
5	Base frame	1	Galvanized steel/Painted	Galvanized steel/Painted	1.4301 (AISI 304)
6	Non-return valve	1 per pump	Brass NiCr- plated or cast iron	Brass NiCr- plated or cast iron	1.4401 (AISI 316)
7	Discharge manifold	1	Galvanized steel	1.4301 (AISI 304)	1.4401 (AISI 316)
8	Pump	1-4	LCR	LCRI	LCRN
9	Diaphragm tank	1	As per customer requirement		

### Dimensions and weights

Dimensions and weights for Aquapack 1000 are stated on pages 18 to 23.

Please note that the dimensions stated may vary  $\pm 20$  mm and that all systems are supplied without vibration dampers. The dimensions may vary according to the technological improvements of the components and/or materials used.

### Flange dimensions

#### PN 16 flanges

Standard: EN 1092-2 PN 16 (1.6 Mpa)	Nominal diameter (DN)						
	DN	80	100	125	150	200	250
$D_1$	80	100	125	150	200	250	
$D_2$	160	180	210	240	295	355	
$D_3$	200	220	250	285	340	405	
S	8x19	8x19	8x19	8x23	12x23	12x28	

# Construction

Booster sets with 2 to 4 LCR pumps

**Aquapack 1000**

## Materials LCR, LCRI, LCRN 2, 3, 5, 10, 15 and 20

Designation	Materials	LCR		LCRI, LCRN	
		EN/DIN	AISI/ASTM	EN/DIN	AISI/ASTM
Pump head	Cast iron EN-GJL-200	EN-JL1030	ASTM 25B	EN-JL1030	ASTM 25B
Pump head cover	Stainless steel	-	-	1.4408	CF 8M eq. to AISI 316
Shaft	Stainless steel	1.4401	AISI 316 AISI 431	1.4401 1.4460	AISI 316 AISI 329
Impeller	Stainless steel	1.4301	AISI 304	1.4301 (LCRI) 1.4401 (LCRN)	AISI 304 (LCRI) AISI 316 (LCRN)
Chamber	Stainless steel	1.4301	AISI 304	1.4301 (LCRI) 1.4401 (LCRN)	AISI 304 (LCRI) AISI 316 (LCRN)
Outer sleeve	Stainless steel	1.4301	AISI 304	1.4301 (LCRI) 1.4401 (LCRN)	AISI 304 (LCRI) AISI 316 (LCRN)
O-ring for outer sleeve	EPDM or FKM				
Base	Cast iron EN-GJL-200 (LCR)/ Stainless steel (LCRI/LCRN)	EN-JL1030	ASTM 25B	1.4408	CF 8M eq. to AISI 316
Neck ring	PTFE				
Rubber parts	EPDM or FKM				

## Materials LCR, LCRN 32 and 45

Designation	Materials	LCR		LCRN	
		EN/DIN	AISI/ASTM	EN/DIN	AISI/ASTM
Pump head	Cast iron EN-GJS-500-7 (LCR)/ Stainless steel (LCRN)	EN-JS1050	ASTM 80-55-06	1.4408	CF 8M eq. to AISI 316
Motor stool	Cast iron EN-GJL-200	EN-JL1030	ASTM 25B	EN-JL1030	ASTM 25B
Shaft	Stainless steel	1.4057	AISI 431	1.4462	
Impeller	Stainless steel	1.4301	AISI 304	1.4401	AISI 316
Chamber	Stainless steel	1.4301	AISI 304	1.4401	AISI 316
Outer sleeve	Stainless steel	1.4301	AISI 304	1.4401	AISI 316
O-ring for outer sleeve	EPDM or FKM				
Base	Cast iron EN-GJS-500-7 (LCR)/ Stainless steel (LCRN)	EN-JS1050	ASTM 80-55-06	1.4408	CF 8M eq. to AISI 316
Neck ring	Carbon-graphite filled PTFE				
Bearing ring	Bronze				
Bottom bearing ring	TC/TC				
Rubber parts	EPDM or FKM				

# Installation

## Booster sets with 2 to 4 LCR pumps

## Aquapack 1000

### Mechanical installation

#### Location

The booster system must be installed in a well-ventilated room to ensure sufficient cooling of the control cabinet and pumps.

**Note:** Aquapack 1000 is not designed for outdoor installation and must not be exposed to direct sunlight.

The booster system should be placed with a 1-metre clearance in front and on the two sides for inspection and removal.

#### Pipework

Arrows on the pump base show the direction of flow of water through the pump.

The pipework connected to the booster system must be of adequate size.

The pipes are connected to the manifolds of the booster system.

To optimize operation and minimize noise and vibration, it may be necessary to consider vibration dampening of the booster system.

Noise and vibration are generated by the rotations in the motor and pump and by the flow in pipework and fittings. The effect on the environment is subjective and depends on correct installation and the state of the remaining system.

If booster systems are installed in blocks of flats or the first consumer on the line is close to the booster system, it is advisable to fit expansion joints on the suction and discharge pipes to prevent vibration being transmitted through the pipework.

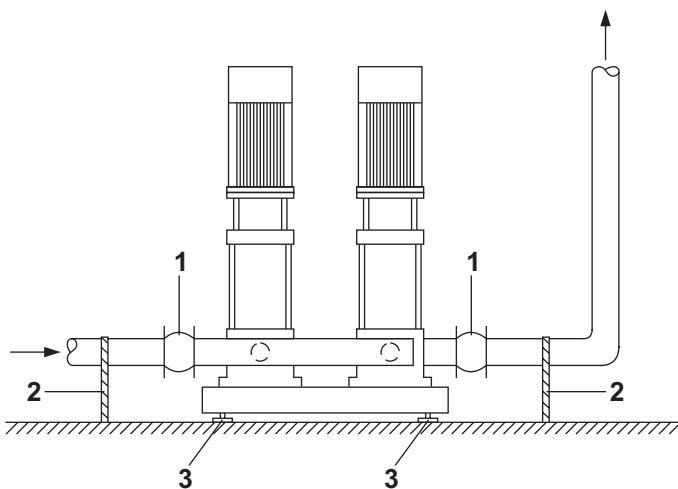

Fig. 6 Schematic view of hydraulic installation

Pos.	Description
1	Expansion joint
2	Pipe support
3	Vibration damper

**Note:** Expansion joints, pipe supports and vibration dampers shown in the fig. 6 are not supplied with a standard booster system.

All nuts should be tightened prior to start-up.

The pipes must be fastened to parts of the building to ensure that they cannot move or be twisted.

#### Foundation

The booster system should be positioned on an even and solid surface, such as a concrete floor or foundation. If the booster system is not fitted with vibration dampers, it must be bolted to the floor or foundation.

**Note:** As a rule of thumb, the weight of a concrete foundation should be 1.5 x the weight of the booster system.

#### Dampening

To prevent the transmission of vibrations to building, it is advisable to isolate the booster system foundation from building parts by mean of vibration dampers.

Which is the right damper varies from installation to installation, and a wrong damper may increase the vibration level. Vibration dampers should therefore be sized by the supplier.

If the booster system is installed on a base frame with vibration dampers, expansion joints should always be fitted on the manifolds. This is important to prevent the booster system from “hanging” in the pipework.

### Electrical installation

The electrical installation should be carried out by an authorized person in accordance with local regulations.

- The electrical installation of the booster set must be carried out in accordance with enclosure class IP 55.
- Make sure that the booster set is suitable for the electricity supply to which it is connected.
- Make sure that the wire cross-section corresponds to the specifications in the wiring diagram.

**Note:** The mains connection should be carried out as shown in the wiring diagram.

# Performance curves

Booster sets with 2 to 4 LCR pumps

# Aquapack 1000 with LCR 2

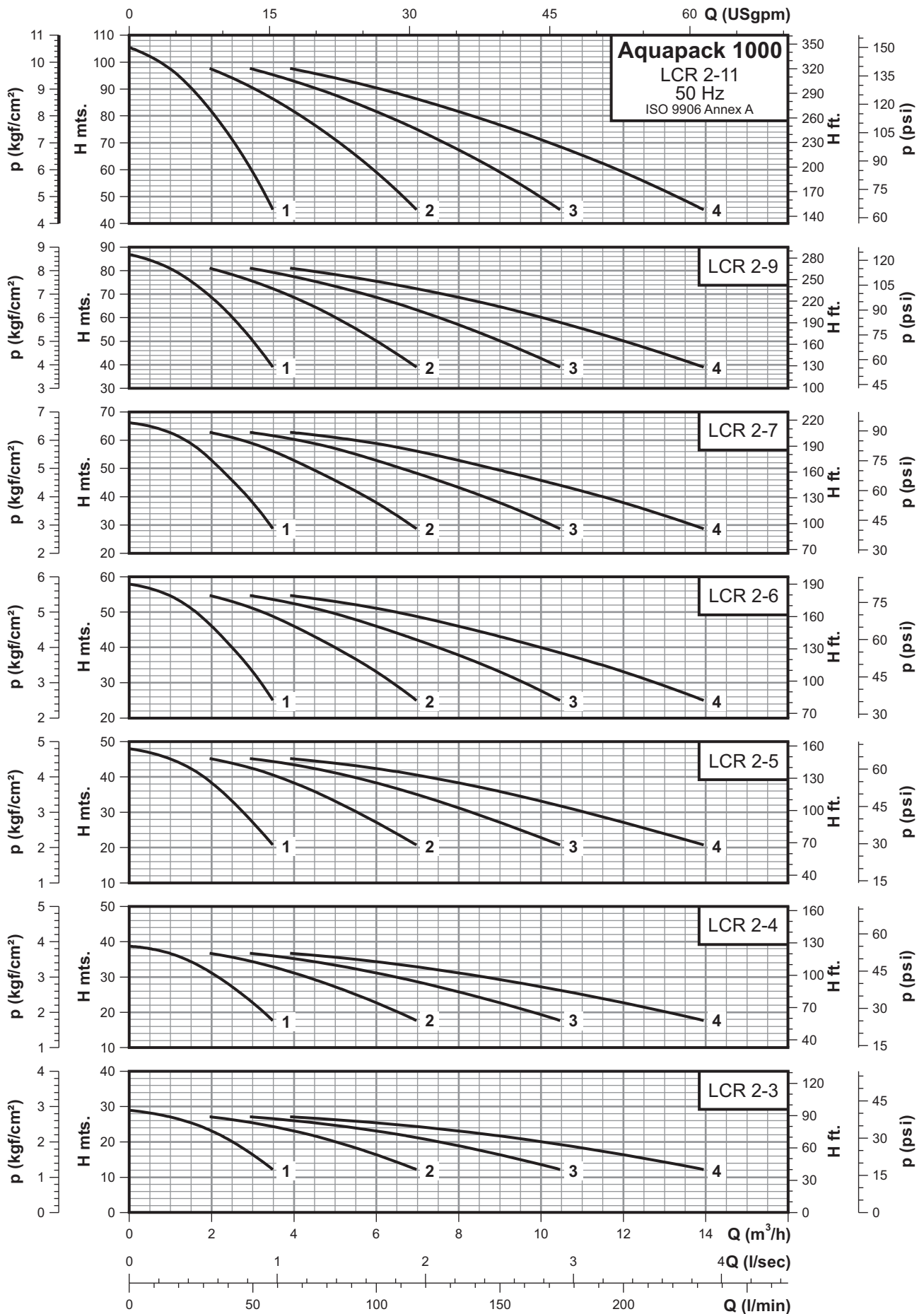

# Performance curves

Booster sets with 2 to 4 LCR pumps

# Aquapack 1000 with LCR 3

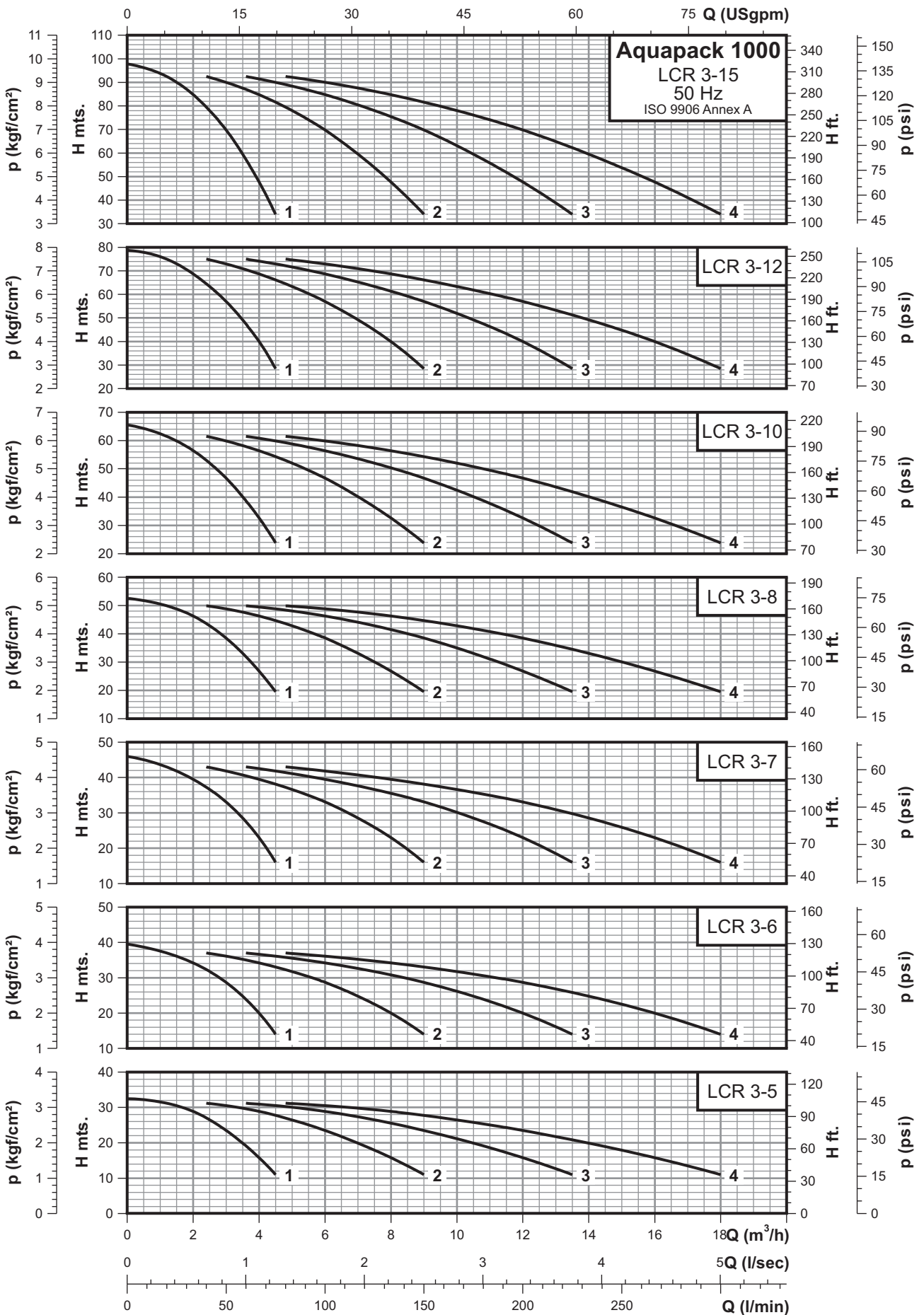



# Performance curves

Booster sets with 2 to 4 LCR pumps

# Aquapack 1000 with LCR 10

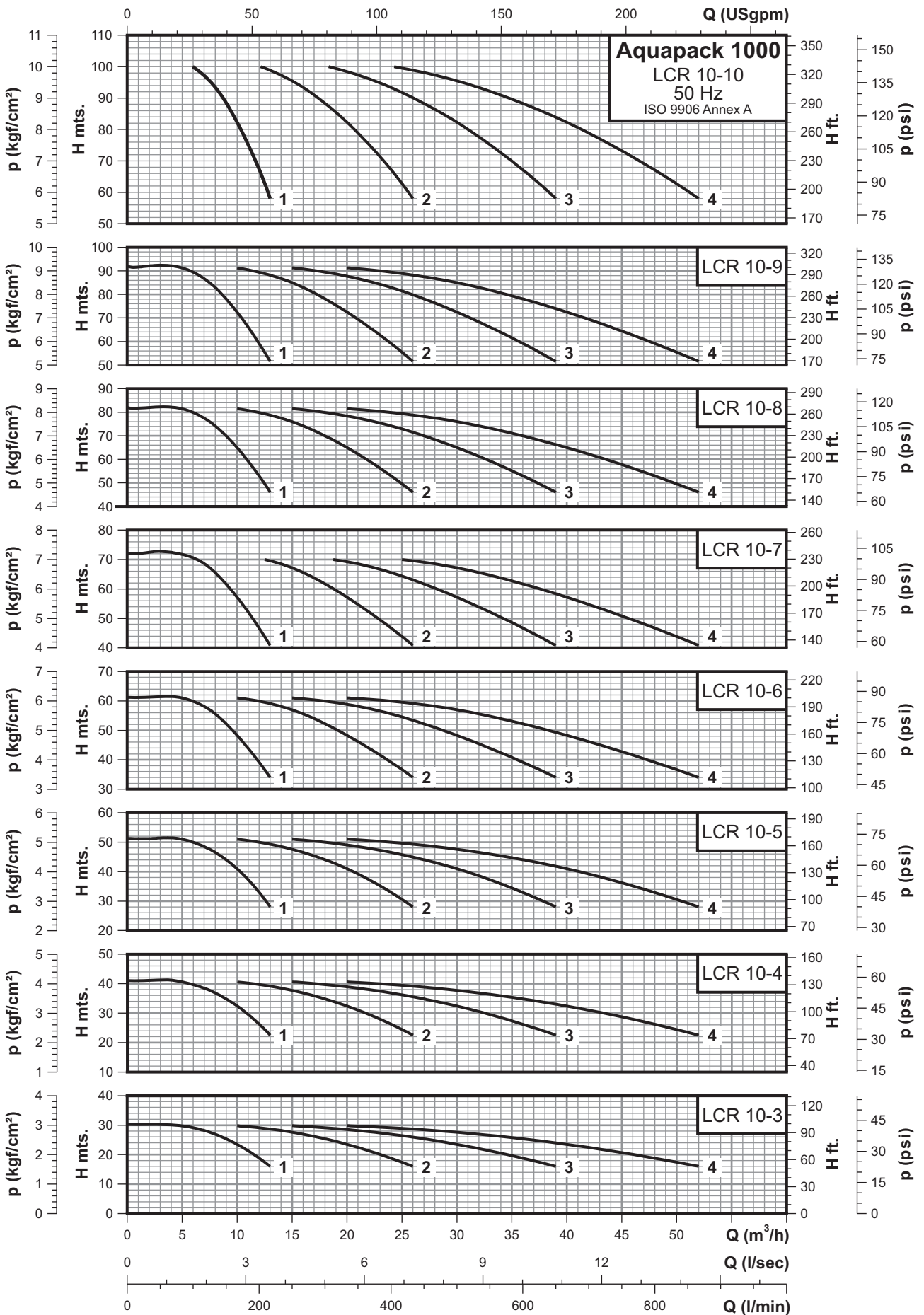

# Performance curves

Booster sets with 2 to 4 LCR pumps

# Aquapack 1000 with LCR 15

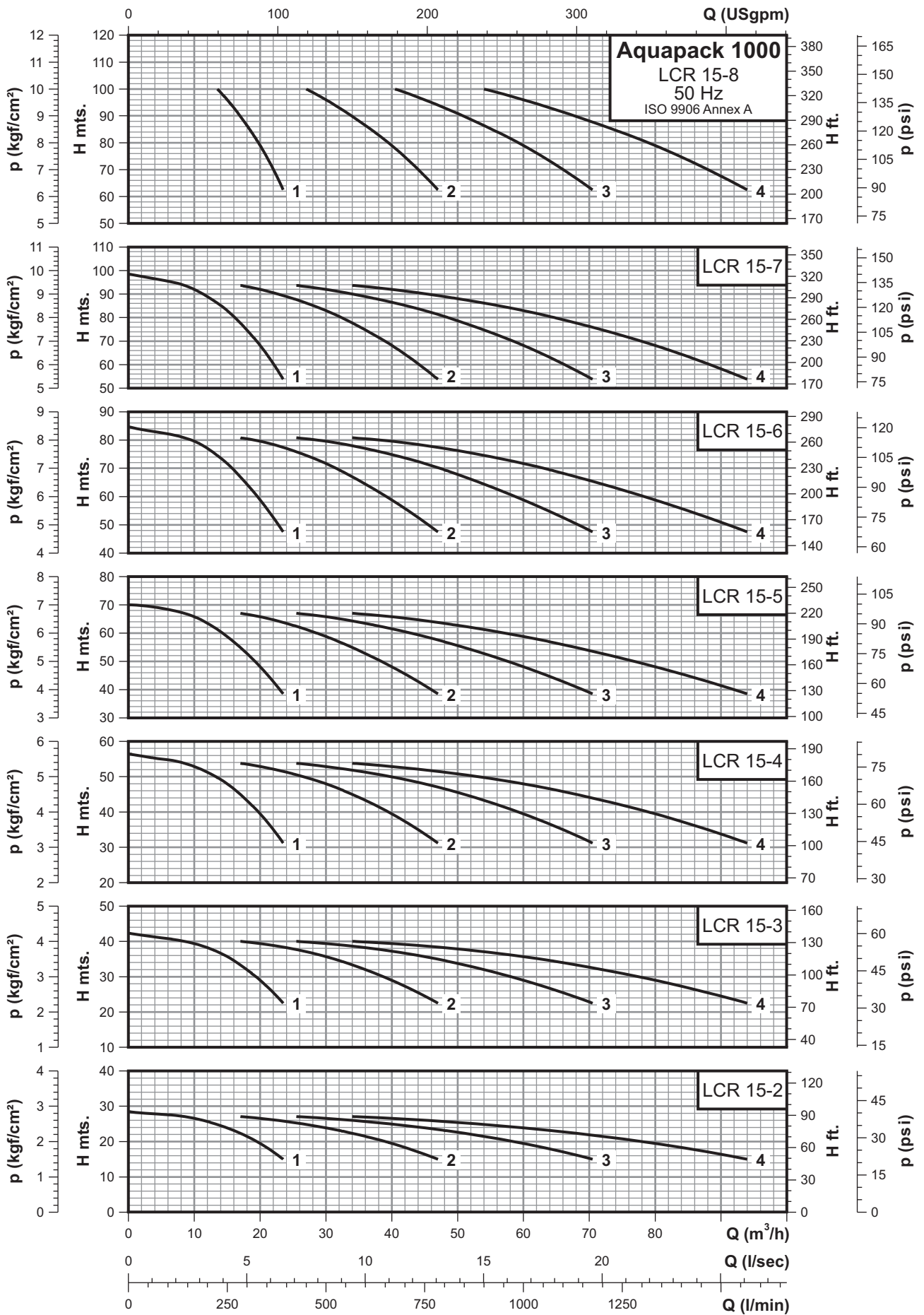

# Performance curves

Booster sets with 2 to 4 LCR pumps

# Aquapack 1000 with LCR 20

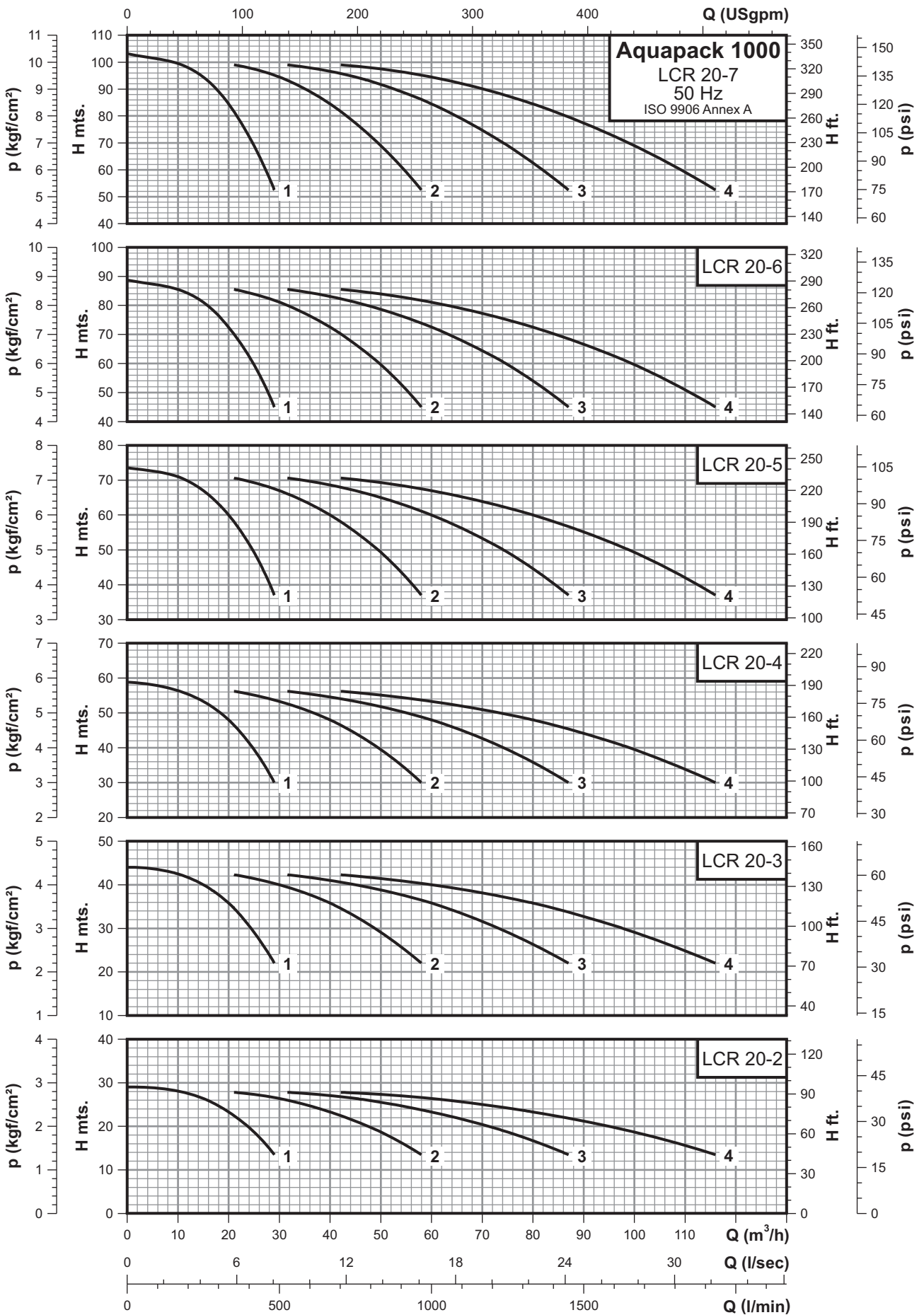

# Performance curves

Booster sets with 2 to 4 LCR pumps

# Aquapack 1000 with LCR 32

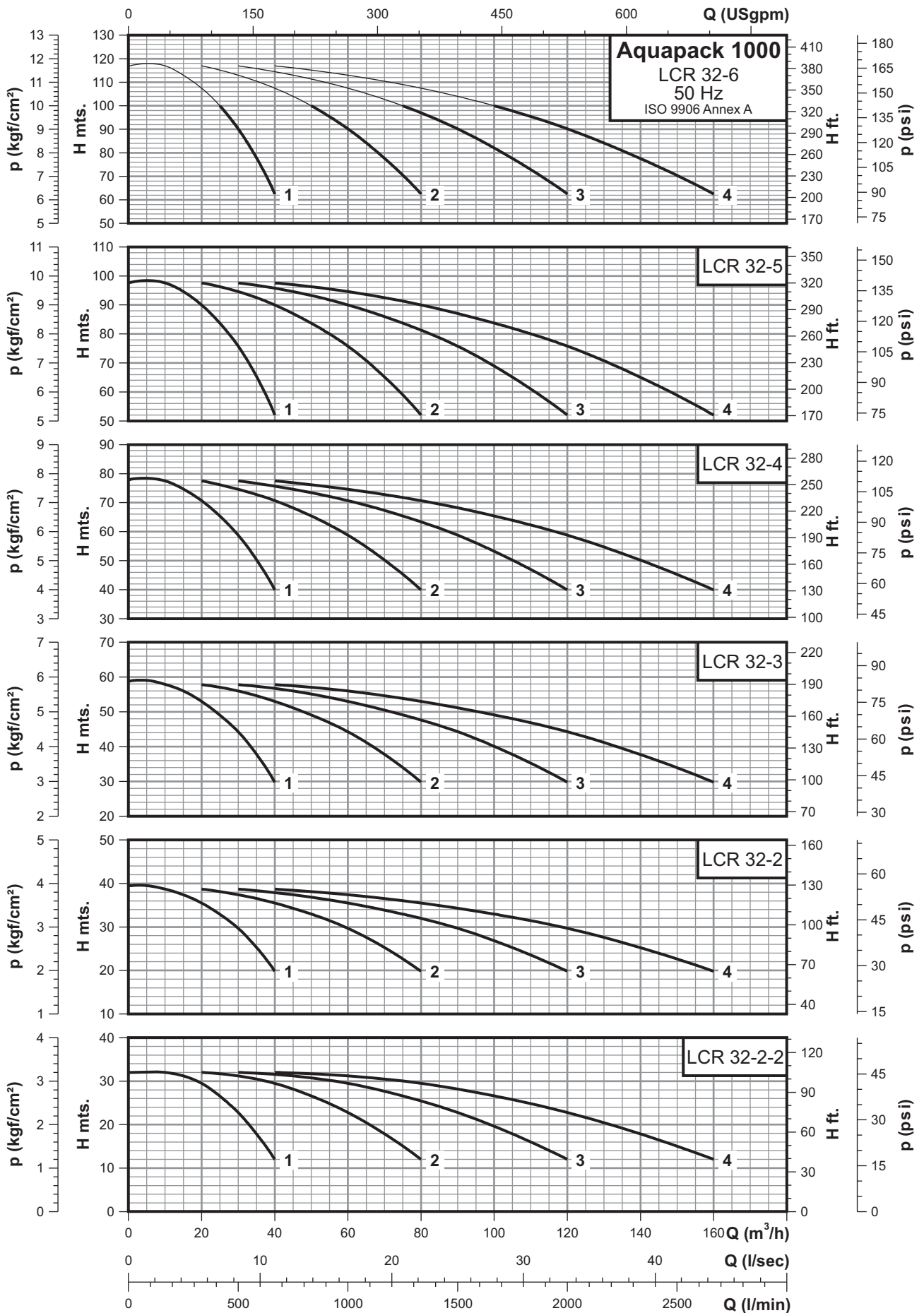

# Performance curves

Booster sets with 2 to 4 LCR pumps

# Aquapack 1000 with LCR 45

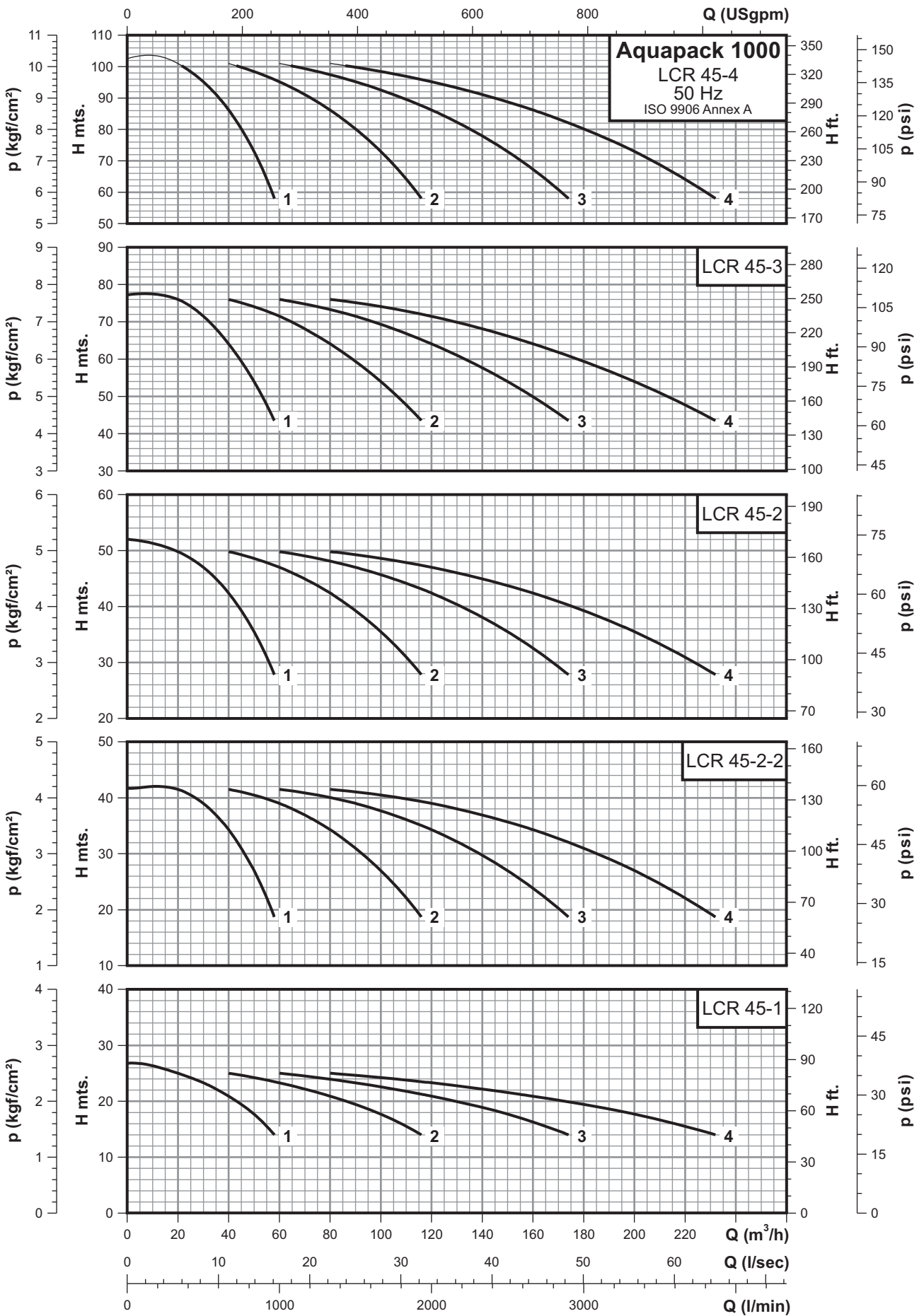

# Dimensions & weights

## Aquapack 1000

Booster sets with 2 to 4 LCR pumps

2 pumps

Booster set with 2 pump

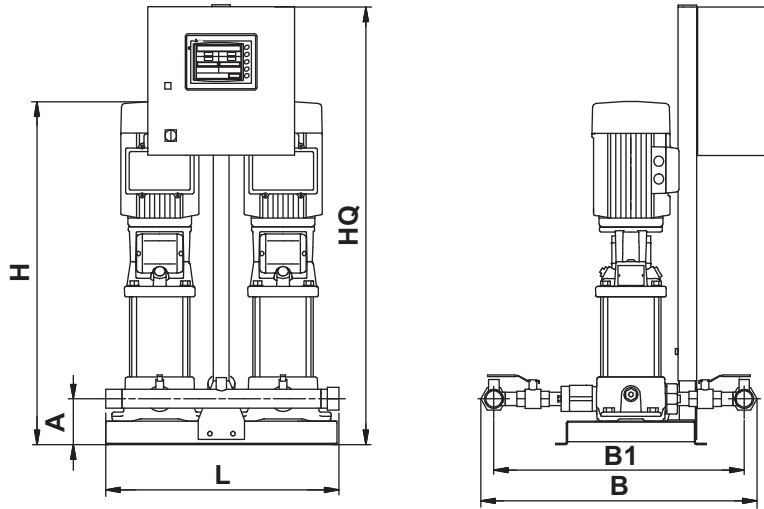

Fig. 7 Dimensional sketch of a Aquapack 1000 booster set with a control cabinet centred the base plate

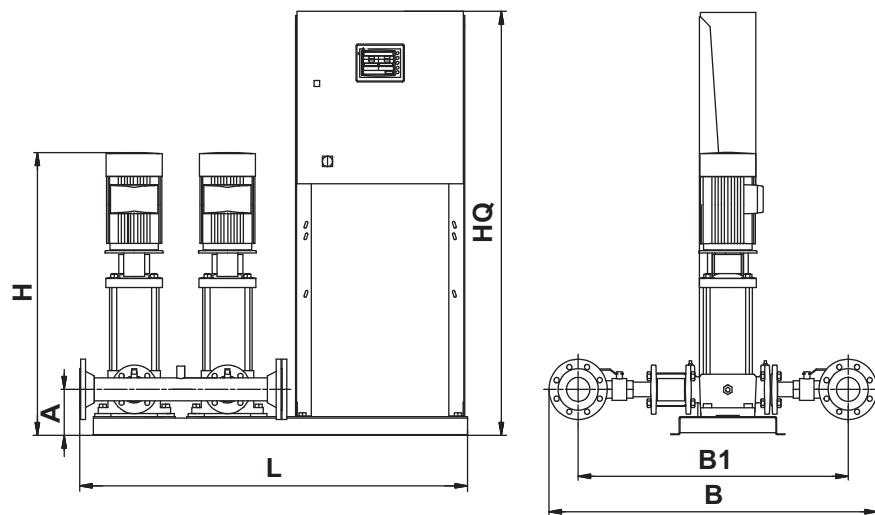

Fig. 8 Aquapack 1000 booster set with a control cabinet mounted on the same base plate as the pumps

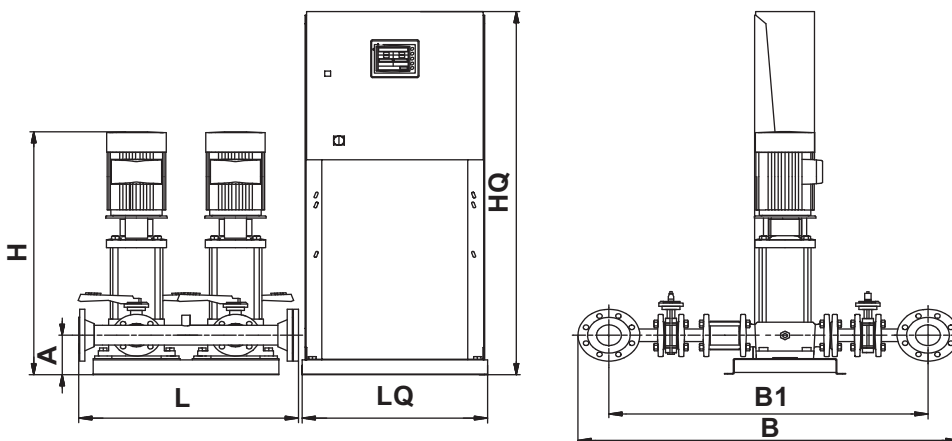

Fig. 9 Aquapack 1000 booster set with a control cabinet mounted on a separate base plate

# Dimensions & weights

# Aquapack 1000 2 pumps

## Booster sets with 2 to 4 LCR pumps

### Booster set with 2 pump

Pump type	Supply voltage [V]	Motor [kW]	Manifold connection	A [mm]	B [mm]	B1 [mm]	L [mm]	LQ [mm]	H [mm]	HQ [mm]	Weight [kg]	Design
2LCR 2-3	3x380-415V	0.37	R 2	120	710	650	610	-	515	1160-1500	108	B
2LCR 2-4	3x380-415V	0.55	R 2	120	710	650	610	-	533	1160-1500	108	B
2LCR 2-5	3x380-415V	0.55	R 2	120	710	650	610	-	551	1160-1500	110	B
2LCR 2-6	3x380-415V	0.75	R 2	120	710	650	610	-	569	1160-1500	112	B
2LCR 2-7	3x380-415V	0.75	R 2	120	710	650	610	-	587	1160-1500	112	B
2LCR 2-9	3x380-415V	1.10	R 2	120	710	650	610	-	623	1160-1500	118	B
2LCR 2-11	3x380-415V	1.10	R 2	120	710	650	610	-	659	1160-1500	121	B
2LCR 3-5	3x380-415V	0.37	R 2	120	710	650	610	-	551	1160-1500	110	B
2LCR 3-6	3x380-415V	0.55	R 2	120	710	650	610	-	569	1160-1500	112	B
2LCR 3-7	3x380-415V	0.55	R 2	120	710	650	610	-	587	1160-1500	112	B
2LCR 3-8	3x380-415V	0.75	R 2	120	710	650	610	-	651	1160-1500	118	B
2LCR 3-10	3x380-415V	0.75	R 2	120	710	650	610	-	687	1160-1500	118	B
2LCR 3-12	3x380-415V	1.10	R 2	120	710	650	610	-	723	1160-1500	126	B
2LCR 3-15	3x380-415V	1.10	R 2	120	710	650	610	-	777	1160-1500	126	B
2LCR 5-5	3x380-415V	0.75	R 2	120	710	650	610	-	642	1160-1500	114	B
2LCR 5-7	3x380-415V	1.10	R 2	120	710	650	610	-	696	1160-1500	122	B
2LCR 5-8	3x380-415V	1.10	R 2	120	710	650	610	-	723	1160-1500	122	B
2LCR 5-9	3x380-415V	1.50	R 2	120	710	650	610	-	816	1160-1500	138	B
2LCR 5-10	3x380-415V	1.50	R 2	120	710	650	610	-	843	1160-1500	138	B
2LCR 5-13	3x380-415V	2.20	R 2	120	710	650	610	-	964	1160-1500	146	B
2LCR 5-15	3x380-415V	2.20	R 2	120	710	650	610	-	1018	1160-1500	146	B
2LCR 10-3	3x380-415V	1.10	R 2½"	150	876	800	670	-	678	1160-1500	144	B
2LCR 10-4	3x380-415V	1.50	R 2½"	150	876	800	670	-	774	1160-1500	160	B
2LCR 10-5	3x380-415V	2.20	R 2½"	150	876	800	670	-	804	1160-1500	166	B
2LCR 10-6	3x380-415V	2.20	R 2½"	150	876	800	670	-	834	1160-1500	166	B
2LCR 10-7	3x380-415V	3.00	R 2½"	150	876	800	670	-	923	1160-1500	180	B
2LCR 10-8	3x380-415V	3.00	R 2½"	150	876	800	670	-	953	1160-1500	180	B
2LCR 10-9	3x380-415V	3.00	R 2½"	150	876	800	670	-	983	1160-1500	180	B
2LCR 10-10	3x380-415V	4.00	R 2½"	150	876	800	670	-	1050	1160-1500	209	B
2LCR 15-2	3x380-415V	2.20	DN 80	160	1150	950	755	-	806	1160-1500	211	B
2LCR 15-3	3x380-415V	3.00	DN 80	160	1150	950	755	-	870	1160-1500	221	B
2LCR 15-4	3x380-415V	4.00	DN 80	160	1150	950	755	-	952	1160-1500	250	B
2LCR 15-5	3x380-415V	4.00	DN 80	160	1150	950	755	-	997	1160-1500	250	B
2LCR 15-6	3x380-415V	5.50	DN 80	160	1150	950	1310	-	1093	1650	282	A
2LCR 15-7	3x380-415V	5.50	DN 80	160	1150	950	1310	-	1138	1650	288	A
2LCR 15-8	3x380-415V	7.50	DN 80	160	1150	950	1310	-	1183	1650	294	A
2LCR 20-2	3x380-415V	2.20	DN 80	160	1150	950	755	-	806	1160-1500	244	B
2LCR 20-3	3x380-415V	4.00	DN 80	160	1150	950	755	-	907	1160-1500	244	B
2LCR 20-4	3x380-415V	5.50	DN 80	160	1150	950	1310	-	1003	1650	282	A
2LCR 20-5	3x380-415V	5.50	DN 80	160	1150	950	1310	-	1048	1650	284	A
2LCR 20-6	3x380-415V	7.50	DN 80	160	1150	950	1310	-	1093	1650	290	A
2LCR 20-7	3x380-415V	7.50	DN 80	160	1150	950	1310	-	1138	1650	292	A
2LCR 32-2-2	3x380-415V	3.00	DN 100	175	1170	950	1037	-	980	1160-1500	342	B
2LCR 32-2	3x380-415V	4.00	DN 100	175	1170	950	1037	-	1017	1160-1500	342	B
2LCR 32-3	3x380-415V	5.50	DN 100	175	1170	950	1037	-	1106	1650	365	A
2LCR 32-4	3x380-415V	7.50	DN 100	175	1170	950	1037	-	1176	1650	381	A
2LCR 32-5	3x380-415V	11.0	DN 100	215	1170	950	1037	600	1504	1650	504	C
2LCR 32-6	3x380-415V	11.0	DN 100	215	1170	950	1037	600	1574	1650	510	C
2LCR 45-1	3x380-415V	4.00	DN 150	210	1335	1050	1042	-	1001	1160-1500	350	A
2LCR 45-2-2	3x380-415V	5.50	DN 150	210	1335	1050	1042	-	1100	1650	368	A
2LCR 45-2	3x380-415V	7.50	DN 150	210	1335	1050	1042	-	1100	1650	378	A
2LCR 45-3	3x380-415V	11.0	DN 150	250	1335	1050	1042	600	1438	1650	554	C
2LCR 45-4	3x380-415V	15.0	DN 150	250	1335	1050	1042	600	1497	1650	597	C

Design A: Aquapack 1000 booster set with a control cabinet mounted on the same base plate as the pumps.

Design B: Aquapack 1000 booster set with a control cabinet centred on the base plate.

Design C: Aquapack 1000 booster set with a floor-mounted control cabinet.

Design D: Aquapack 1000 booster set with a control cabinet mounted on a separate base plate.

Dimensions may vary by ±20 mm.

# Dimensions & weights

Booster sets with 2 to 4 LCR pumps

## Aquapack 1000

### 3 pumps

Booster set with 3 pump

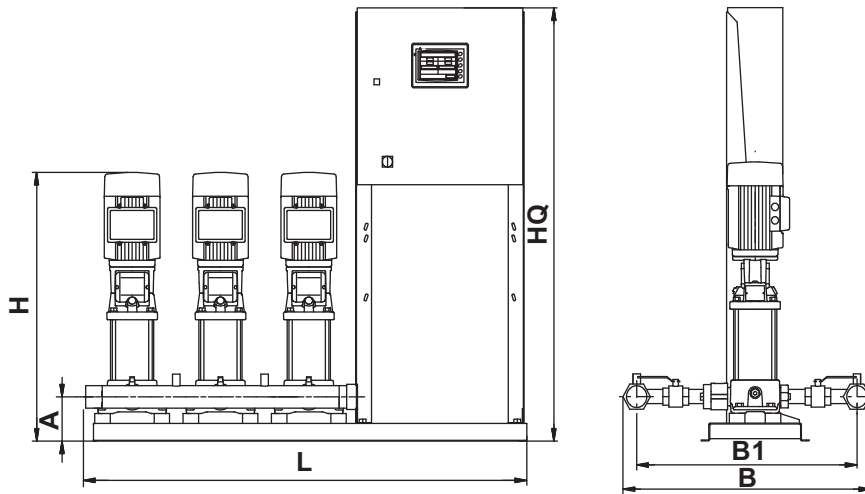

Fig. 10 Aquapack 1000 booster set with a control cabinet mounted on the same base plate as the pumps

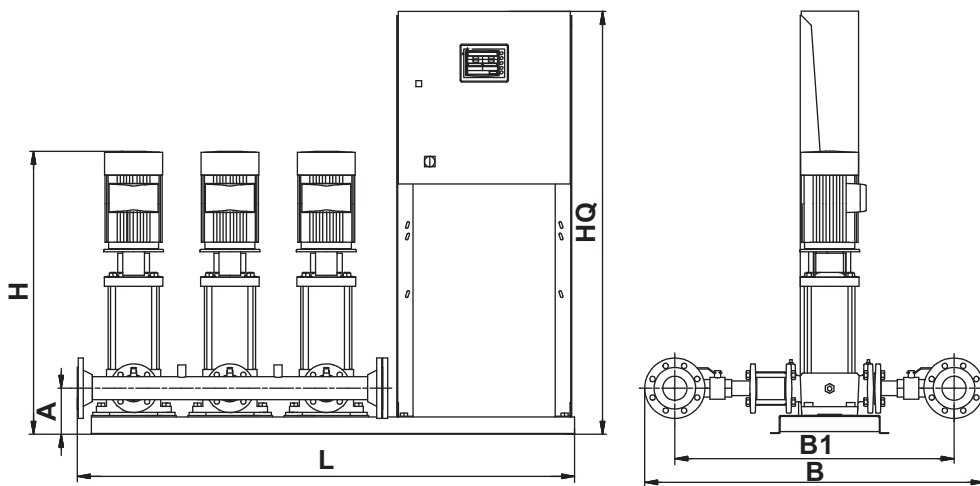

Fig. 11 Aquapack 1000 booster set with a control cabinet mounted on the same base plate as the pumps

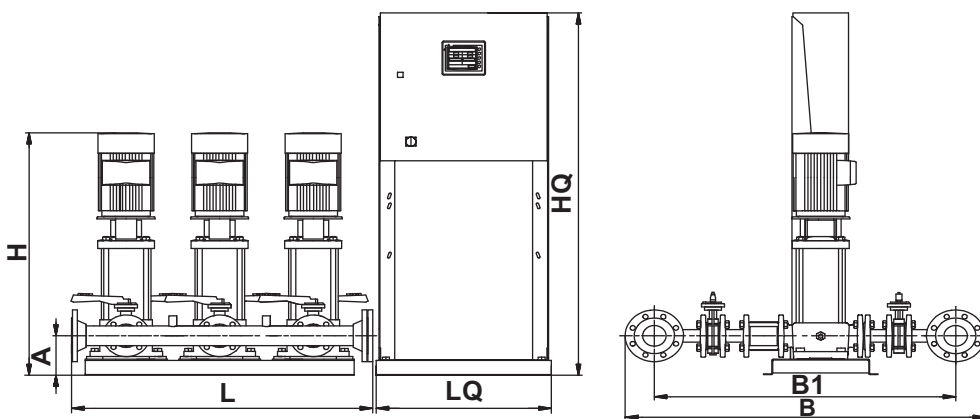

Fig. 12 Aquapack 1000 booster set with a control cabinet mounted on a separate base plate

# Dimensions & weights

## Aquapack 1000

### Booster sets with 2 to 4 LCR pumps

### 3 pumps

#### Booster set with 3 pump

Pump type	Supply voltage [V]	Motor [kW]	Manifold connection	A [mm]	B [mm]	B1 [mm]	L [mm]	LQ [mm]	H [mm]	HQ [mm]	Weight [kg]	Design
3LCR 2-3	3x380-415V	0.37	R 2	120	710	650	1370	-	515	1650	169	A
3LCR 2-4	3x380-415V	0.55	R 2	120	710	650	1370	-	533	1650	169	A
3LCR 2-5	3x380-415V	0.55	R 2	120	710	650	1370	-	551	1650	172	A
3LCR 2-6	3x380-415V	0.75	R 2	120	710	650	1370	-	569	1650	175	A
3LCR 2-7	3x380-415V	0.75	R 2	120	710	650	1370	-	587	1650	175	A
3LCR 2-9	3x380-415V	1.10	R 2	120	710	650	1370	-	623	1650	184	A
3LCR 2-11	3x380-415V	1.10	R 2	120	710	650	1370	-	659	1650	190	A
3LCR 3-5	3x380-415V	0.37	R 2	120	710	650	1370	-	551	1650	172	A
3LCR 3-6	3x380-415V	0.55	R 2	120	710	650	1370	-	569	1650	175	A
3LCR 3-7	3x380-415V	0.55	R 2	120	710	650	1370	-	587	1650	175	A
3LCR 3-8	3x380-415V	0.75	R 2	120	710	650	1370	-	651	1650	184	A
3LCR 3-10	3x380-415V	0.75	R 2	120	710	650	1370	-	687	1650	184	A
3LCR 3-12	3x380-415V	1.10	R 2	120	710	650	1370	-	723	1650	196	A
3LCR 3-15	3x380-415V	1.10	R 2	120	710	650	1370	-	777	1650	196	A
3LCR 5-5	3x380-415V	0.75	R 2	120	710	650	1370	-	642	1650	179	A
3LCR 5-7	3x380-415V	1.10	R 2	120	710	650	1370	-	696	1650	191	A
3LCR 5-8	3x380-415V	1.10	R 2	120	710	650	1370	-	723	1650	191	A
3LCR 5-9	3x380-415V	1.50	R 2	120	710	650	1370	-	816	1650	215	A
3LCR 5-10	3x380-415V	1.50	R 2	120	710	650	1370	-	843	1650	215	A
3LCR 5-13	3x380-415V	2.20	R 2	120	710	650	1370	-	964	1650	227	A
3LCR 5-15	3x380-415V	2.20	R 2	120	710	650	1370	-	1018	1650	227	A
3LCR 10-3	3x380-415V	1.10	R 2½"	150	876	800	1400	-	678	1650	223	A
3LCR 10-4	3x380-415V	1.50	R 2½"	150	876	800	1400	-	774	1650	247	A
3LCR 10-5	3x380-415V	2.20	R 2½"	150	876	800	1400	-	804	1650	256	A
3LCR 10-6	3x380-415V	2.20	R 2½"	150	876	800	1400	-	834	1650	256	A
3LCR 10-7	3x380-415V	3.00	R 2½"	150	876	800	1400	-	923	1650	277	A
3LCR 10-8	3x380-415V	3.00	R 2½"	150	876	800	1400	-	953	1650	277	A
3LCR 10-9	3x380-415V	3.00	R 2½"	150	876	800	1400	-	983	1650	277	A
3LCR 10-10	3x380-415V	4.00	R 2½"	150	876	800	1400	-	1050	1650	320	A
3LCR 15-2	3x380-415V	2.20	DN 100	160	1170	950	1430	-	806	1650	322	A
3LCR 15-3	3x380-415V	3.00	DN 100	160	1170	950	1430	-	870	1650	337	A
3LCR 15-4	3x380-415V	4.00	DN 100	160	1170	950	1430	-	952	1650	380	A
3LCR 15-5	3x380-415V	4.00	DN 100	160	1170	950	1430	-	997	1650	380	A
3LCR 15-6	3x380-415V	5.50	DN 100	160	1170	950	1630	-	1093	1650	416	A
3LCR 15-7	3x380-415V	5.50	DN 100	160	1170	950	1630	-	1138	1650	425	A
3LCR 15-8	3x380-415V	7.50	DN 100	160	1170	950	1630	-	1183	1650	434	A
3LCR 20-2	3x380-415V	2.20	DN 100	160	1170	950	1430	-	806	1650	371	A
3LCR 20-3	3x380-415V	4.00	DN 100	160	1170	950	1430	-	907	1650	371	A
3LCR 20-4	3x380-415V	5.50	DN 100	160	1170	950	1630	-	1003	1650	416	A
3LCR 20-5	3x380-415V	5.50	DN 100	160	1170	950	1630	-	1048	1650	418	A
3LCR 20-6	3x380-415V	7.50	DN 100	160	1170	950	1630	-	1093	1650	428	A
3LCR 20-7	3x380-415V	7.50	DN 100	160	1170	950	1630	-	1138	1650	431	A
3LCR 32-2-2	3x380-415V	3.00	DN 150	175	1235	950	1542	-	980	1650	522	A
3LCR 32-2	3x380-415V	4.00	DN 150	175	1235	950	1542	-	1017	1650	522	A
3LCR 32-3	3x380-415V	5.50	DN 150	175	1235	950	1542	-	1106	1650	511	A
3LCR 32-4	3x380-415V	7.50	DN 150	175	1235	950	1542	-	1176	1650	589	A
3LCR 32-5	3x380-415V	11.0	DN 150	215	1235	950	1542	1000	1504	1650	771	C
3LCR 32-6	3x380-415V	11.0	DN 150	215	1235	950	1542	1000	1574	1650	780	C
3LCR 45-1	3x380-415V	4.00	DN 200	210	1390	1050	1544	-	1001	1650	562	A
3LCR 45-2-2	3x380-415V	5.50	DN 200	210	1390	1050	1544	-	1100	1650	576	A
3LCR 45-2	3x380-415V	7.50	DN 200	210	1390	1050	1544	-	1100	1650	713	A
3LCR 45-3	3x380-415V	11.0	DN 200	250	1390	1050	1544	1000	1438	1650	808	C
3LCR 45-4	3x380-415V	15.0	DN 200	250	1390	1050	1544	1000	1497	1650	872	C

Design A: Aquapack 1000 booster set with a control cabinet mounted on the same base plate as the pumps.

Design B: Aquapack 1000 booster set with a control cabinet centred on the base plate.

Design C: Aquapack 1000 booster set with a floor-mounted control cabinet.

Design D: Aquapack 1000 booster set with a control cabinet mounted on a separate base plate.

Dimensions may vary by ±20 mm.

# Dimensions & weights

Booster sets with 2 to 4 LCR pumps

## Aquapack 1000

### 4 pumps

Booster set with 4 pump

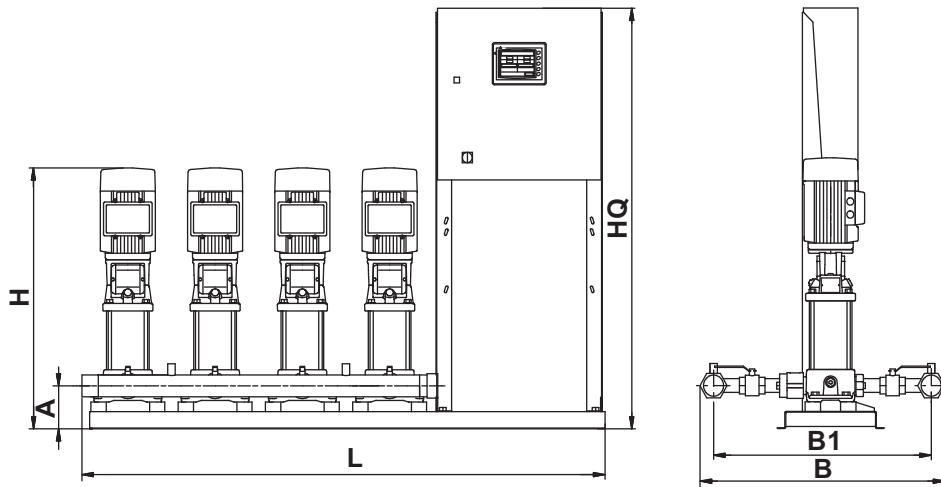

Fig. 13 Aquapack 1000 booster set with a control cabinet mounted on the same base plate as the pumps

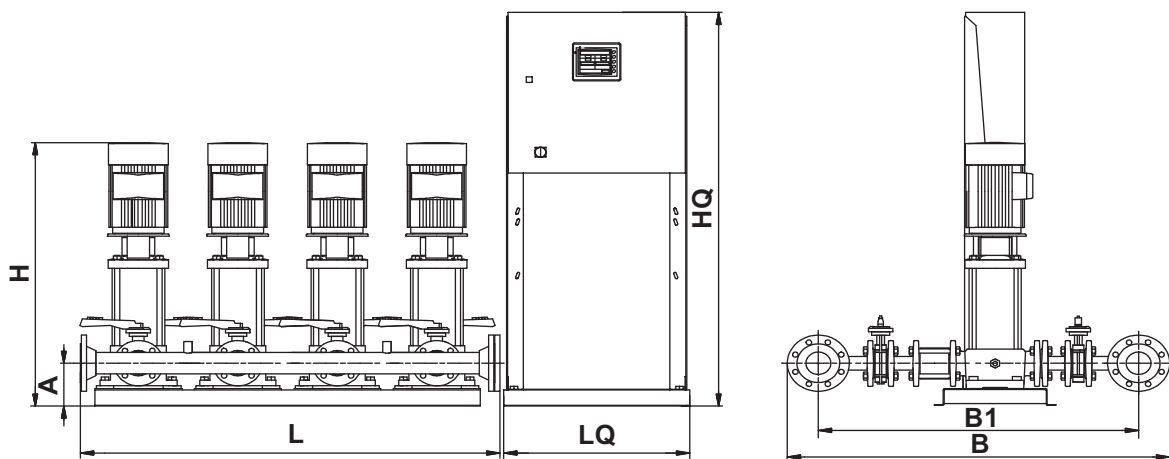

Fig. 14 Aquapack 1000 booster set with a control cabinet mounted on a separate base plate

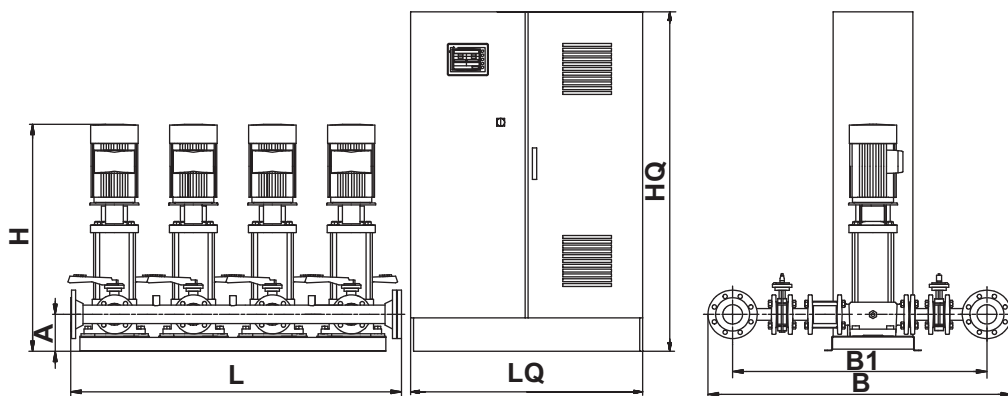

Fig. 15 Aquapack 1000 booster set with a floor-mounted control cabinet

# Dimensions & weights

# Aquapack 1000 4 pumps

## Booster sets with 2 to 4 LCR pumps

### Booster set with 4 pump

Pump type	Supply voltage [V]	Motor [kW]	Manifold connection	A [mm]	B [mm]	B1 [mm]	L [mm]	LQ [mm]	H [mm]	HQ [mm]	Weight [kg]	Design
4LCR 2-3	3x380-415V	0.37	R 2½"	120	726	650	1690	-	515	1650	213	A
4LCR 2-4	3x380-415V	0.55	R 2½"	120	726	650	1690	-	533	1650	213	A
4LCR 2-5	3x380-415V	0.55	R 2½"	120	726	650	1690	-	551	1650	217	A
4LCR 2-6	3x380-415V	0.75	R 2½"	120	726	650	1690	-	569	1650	221	A
4LCR 2-7	3x380-415V	0.75	R 2½"	120	726	650	1690	-	587	1650	221	A
4LCR 2-9	3x380-415V	1.10	R 2½"	120	726	650	1690	-	623	1650	233	A
4LCR 2-11	3x380-415V	1.10	R 2½"	120	726	650	1690	-	659	1650	241	A
4LCR 3-5	3x380-415V	0.37	R 2½"	120	726	650	1690	-	551	1650	217	A
4LCR 3-6	3x380-415V	0.55	R 2½"	120	726	650	1690	-	569	1650	221	A
4LCR 3-7	3x380-415V	0.55	R 2½"	120	726	650	1690	-	587	1650	221	A
4LCR 3-8	3x380-415V	0.75	R 2½"	120	726	650	1690	-	651	1650	233	A
4LCR 3-10	3x380-415V	0.75	R 2½"	120	726	650	1690	-	687	1650	233	A
4LCR 3-12	3x380-415V	1.10	R 2½"	120	726	650	1690	-	723	1650	249	A
4LCR 3-15	3x380-415V	1.10	R 2½"	120	726	650	1690	-	777	1650	249	A
4LCR 5-5	3x380-415V	0.75	R 2½"	120	726	650	1690	-	642	1650	226	A
4LCR 5-7	3x380-415V	1.10	R 2½"	120	726	650	1690	-	696	1650	242	A
4LCR 5-8	3x380-415V	1.10	R 2½"	120	726	650	1690	-	723	1650	242	A
4LCR 5-9	3x380-415V	1.50	R 2½"	120	726	650	1690	-	816	1650	274	A
4LCR 5-10	3x380-415V	1.50	R 2½"	120	726	650	1690	-	843	1650	274	A
4LCR 5-13	3x380-415V	2.20	R 2½"	120	726	650	1690	-	964	1650	290	A
4LCR 5-15	3x380-415V	2.20	R 2½"	120	726	650	1690	-	1018	1650	290	A
4LCR 10-3	3x380-415V	1.10	DN 80	150	1000	800	1720	-	678	1650	305	A
4LCR 10-4	3x380-415V	1.50	DN 80	150	1000	800	1720	-	774	1650	337	A
4LCR 10-5	3x380-415V	2.20	DN 80	150	1000	800	1720	-	804	1650	349	A
4LCR 10-6	3x380-415V	2.20	DN 80	150	1000	800	1720	-	834	1650	349	A
4LCR 10-7	3x380-415V	3.00	DN 80	150	1000	800	1720	-	923	1650	377	A
4LCR 10-8	3x380-415V	3.00	DN 80	150	1000	800	1720	-	953	1650	377	A
4LCR 10-9	3x380-415V	3.00	DN 80	150	1000	800	1720	-	983	1650	377	A
4LCR 10-10	3x380-415V	4.00	DN 80	150	1000	800	1720	-	1050	1650	434	A
4LCR 15-2	3x380-415V	2.20	DN 100	160	1170	950	1750	-	806	1650	401	A
4LCR 15-3	3x380-415V	3.00	DN 100	160	1170	950	1750	-	870	1650	421	A
4LCR 15-4	3x380-415V	4.00	DN 100	160	1170	950	1750	-	952	1650	478	A
4LCR 15-5	3x380-415V	4.00	DN 100	160	1170	950	1750	-	997	1650	478	A
4LCR 15-6	3x380-415V	5.50	DN 100	160	1170	950	1950	-	1093	1650	560	A
4LCR 15-7	3x380-415V	5.50	DN 100	160	1170	950	1950	-	1138	1650	572	A
4LCR 15-8	3x380-415V	7.50	DN 100	160	1170	950	1950	1000	1183	1650	584	C
4LCR 20-2	3x380-415V	2.20	DN 100	160	1170	950	1750	-	806	1650	466	A
4LCR 20-3	3x380-415V	4.00	DN 100	160	1170	950	1750	-	907	1650	466	A
4LCR 20-4	3x380-415V	5.50	DN 100	160	1170	950	1950	-	1003	1650	560	A
4LCR 20-5	3x380-415V	5.50	DN 100	160	1170	950	1950	-	1048	1650	568	A
4LCR 20-6	3x380-415V	7.50	DN 100	160	1170	950	1950	1000	1093	1650	576	C
4LCR 20-7	3x380-415V	7.50	DN 100	160	1170	950	1950	1000	1138	1650	580	C
4LCR 32-2-2	3x380-415V	3.00	DN 150	175	1235	950	2042	-	980	1650	660	A
4LCR 32-2	3x380-415V	4.00	DN 150	175	1235	950	2042	-	1017	1650	660	A
4LCR 32-3	3x380-415V	5.50	DN 150	175	1235	950	2042	-	1106	1650	781	A
4LCR 32-4	3x380-415V	7.50	DN 150	175	1235	950	2042	1000	1176	1650	813	C
4LCR 32-5	3x380-415V	11.0	DN 150	215	1235	950	2042	1000	1504	1650	986	C
4LCR 32-6	3x380-415V	11.0	DN 150	215	1235	950	2042	1000	1574	1650	998	C
4LCR 45-1	3x380-415V	4.00	DN 200	210	1390	1050	2044	-	1001	1650	802	A
4LCR 45-2-2	3x380-415V	5.50	DN 200	210	1390	1050	2044	-	1100	1650	822	A
4LCR 45-2	3x380-415V	7.50	DN 200	210	1390	1050	2044	1000	1100	1650	912	C
4LCR 45-3	3x380-415V	11.0	DN 200	250	1390	1050	2044	1000	1438	1650	1028	C
4LCR 45-4	3x380-415V	15.0	DN 200	250	1390	1050	2044	1000	1497	1650	1133	C

Design A: Aquapack 1000 booster set with a control cabinet mounted on the same base plate as the pumps.

Design B: Aquapack 1000 booster set with a control cabinet centred on the base plate.

Design C: Aquapack 1000 booster set with a floor-mounted control cabinet.

Design D: Aquapack 1000 booster set with a control cabinet mounted on a separate base plate.

Dimensions may vary by ±20 mm.

# Diaphragm tank

## Booster sets with 2 to 4 LCR pumps

## Aquapack 1000

### Diaphragm tank selection

To ensure stable operation, the Aquapack 1000 booster set must be installed in combination with an adequate diaphragm tank.

The size of the obligatory diaphragm tank can be calculated by means of the following formula:

$$V = \frac{Q \times 1000 \times (1 + (\text{Cut-in}) + \Delta p)}{4 \times n_{\max} \times \Delta p} \times \frac{1}{k}$$

- V = Tank volume [litres]  
 Q = Mean flow [m<sup>3</sup>/h]  
 Δp = Difference between cut-in and cut-out pressure  
 Cut-in = Cut-in pressure (lowest) [bar]  
 k = Constant for diaphragm tank pre-charge pressure:  
 k = 0.9  
 n<sub>max</sub> = Max. numbers of starts/stops per hour

The diaphragm tank pre-charge pressure is set to 0.9 times the lowest cut-in pressure.

Minimum diaphragm tank volume [litres] at Δp = 1.5 [bar] and n<sub>max</sub> = 30:

Pump type	Minimum diaphragm tank volume [litres]							
	Cut-in 1 [bar]	Cut-in 2 [bar]	Cut-in 3 [bar]	Cut-in 4 [bar]	Cut-in 5 [bar]	Cut-in 6 [bar]	Cut-in 7 [bar]	Cut-in 8 [bar]
LCR 2	43	56	68	80	93	105	117	130
LCR 3	65	84	102	120	140	158	176	195
LCR 5	108	135	170	200	232	263	294	324
LCR 10	173	222	272	321	370	420	469	518
LCR 15	346	444	543	642	741	839	938	1037
LCR 20	432	556	679	802	926	1049	1173	1296
LCR 32	691	889	1086	1284	1481	1679	1876	2074
LCR 45	972	1250	1528	1805	2083	2361	2639	2916

Minimum diaphragm tank volume [litres] at Δp = 1.5 [bar] and n<sub>max</sub> = 100:

Pump type	Minimum diaphragm tank volume [litres]							
	Cut-in 1 [bar]	Cut-in 2 [bar]	Cut-in 3 [bar]	Cut-in 4 [bar]	Cut-in 5 [bar]	Cut-in 6 [bar]	Cut-in 7 [bar]	Cut-in 8 [bar]
LCR 2	13	17	20	24	28	31	35	39
LCR 3	20	25	30	36	42	47	53	59
LCR 5	33	41	51	60	70	78	88	98
LCR 10	52	67	81	96	111	126	141	156
LCR 15	104	133	163	193	222	252	281	311
LCR 20	130	167	204	241	278	315	352	389
LCR 32	207	267	326	385	444	504	563	622
LCR 45	292	375	458	542	625	708	792	875

Note: Refer to the cut-in pressure closest to the lowest setting of the selected booster set.

The diaphragm tank may also be selected on the basis of the below tables in which the following values have been used:

Motors up to and including 3.0 kW: n = 30 to 100

Motors above 3.0 kW: n = 10 to 30

Diff. between cut-in and cut-out: Δp = 1.5 [bar]

Lubi pumps and motors are not subject to any particular limitations as they are tested up to 100 start/stops per hour.

However when dimensioning the diaphragm tank volume the following parameters may also be considered:

- Maximum number of start/stops per hour allowed by local regulations
- Maximum number of start/stops per hour described by the system designer
- Temperature and ventilation conditions
- Available space for diaphragm tank installation.







## LUBI INDUSTRIES LLP

Near Kalyan Mills, Naroda Road, Ahmedabad-380 025, INDIA.  
Phone : +91 - 79 - 30610100, Fax No. :+91 - 79 - 30610300.

**Sales Enquiries:** [mktsales@lubipumps.com](mailto:mktsales@lubipumps.com), [expsales@lubipumps.com](mailto:expsales@lubipumps.com)

**[www.lubipumps.com](http://www.lubipumps.com)**



*Product Improvement is a continuous process at 'LUBI'. The data given in this publication is therefore subject to revision.* **Toll Free Service Hotline for India : 1800 3000 3055**